



Infrared Analyser model 8869

Multi-Gas analyser for field applications in safe area and hazardous area with the best ATEX protection mode (Zone 1 / 21).



8869

www.adev.it

Rugged process analyser for measuring up to 3 IR-absorbing gases in heavy duty applications

8869 is a process analyser designed to measure up to 3 IR-absorbing gases with a unique sensing unit. Precision optical filters minimize effects of background gases.

Fast response time and excellent stability are guaranteed by the single beam source and by the elimination of gas-filled cells.

Designed to withstand the most severe process conditions, this resilient analyser has no choppers or other moving parts that may affect the reliability. The sensing unit can be easily disassembled for field maintenance and cleaning.

All parts contacted by gas are made in selected materials making the analyser usable with gas like pure Ammonia, VCM, HCl and other demanding streams.

A unique source-emission control system allows up to 20% windows fouling without effect on accuracy.

The sensing unit of 8869 infrared analyser can be supplied in a general purpose or explosion-proof housing for installation in hazardous area, Zone 1 / Zone 21 (ATEX). Both types of housing are rugged cast aluminum construction which allows reliable operation under adverse ambient conditions.

Infrared Analyser

For industrial process applications



Technical Specification

8869 Infrared Analyser

Performance Specification

Accuracy	± 1% of span (output signal). Further improvable with autocalibration.
Repeatability	± 0.3% of span (short term).
Reproducibility	24 hours: ± 1% of span.
Linearity	with control unit: better than ± 0.5% of full scale
Response Time	Initial: less than 1 sec.; 90% of step-change: 6 sec. (with max. 1000 cc/min. flow rate)
Drift (without autocalibration)	Zero: max. ± 1% of span per week Span: max ± 1% of span per week
Amb. Temp. Influence	± 0.05% of span per °C
Atm. Pressure Influence	± 0.1 ÷ 0.18 % of reading per hPa
Flow Rate Influence	< 0.5% of span over flow variation from 250 to 2000 cc/min.
Line Voltage Influence	max. 0.02% of span, for each 1% change of power voltage.
Gas Interference	Depending of gas. Typically less than 2% of span

Operative Specification

Sample Requirements	Flow Rate: 250 ÷ 2000 cc/min. Pressure: min. 3000 Pa (with filter & flow meter).
Output	non-normalized output current that functions as input of the selected ADEV control unit
Relative Humidity	90% maximum.
Operation Temperature	-10 ÷ +50°C (14 to 122 °F).
Temperature controlled	at 65°C (or higher depending on the application)
Storage Temperature	+70°C (158 °F) max.
Power Requirements	24 ÷ 30 Vdc, 45 VA from dedicated power supplier.
Pneumatic Connections	¼" or 6 mm OD tubing (compression fittings)
Wiring Connections	2 openings for GK 1/2" (cable grip or conduit).

Physical Specification

Wet Parts Materials	316SS, Teflon, Viton, Buna-N, Calcium Fluoride, Quartz, Gold
Dimensions & Weight	200 x 553 (max.) x 154 mm ; 8 Kg.
Finish	Epoxy grey textured enamel
Protection	IP 65 (watertight and dust tight)



Key Applications

- Heat treatments (furnace atmosphere, carburizing, nitriding)
- Iron and steel industry
- Blast furnaces and combustion processes
- Sulphur Production
- Biogas & Landfill Gas
- Gas production industry (gas purity)
- Copper melting furnaces
- Water measurement in high concentration and at high temperature
- ETO sterilizing processes
- in general, selective measurement of any gas with infrared absorption spectrum



Sampling System

The 8869 needs an external sampling system able to deliver an almost clean sample gas to the analyser at the proper temperature, pressure and flow rate.

ADEV has a wide experience in process and can provide the 8869 analyser combined with a sample and condition system designed for the specific application requirements. Contact ADEV for details.



Outline Dimensions

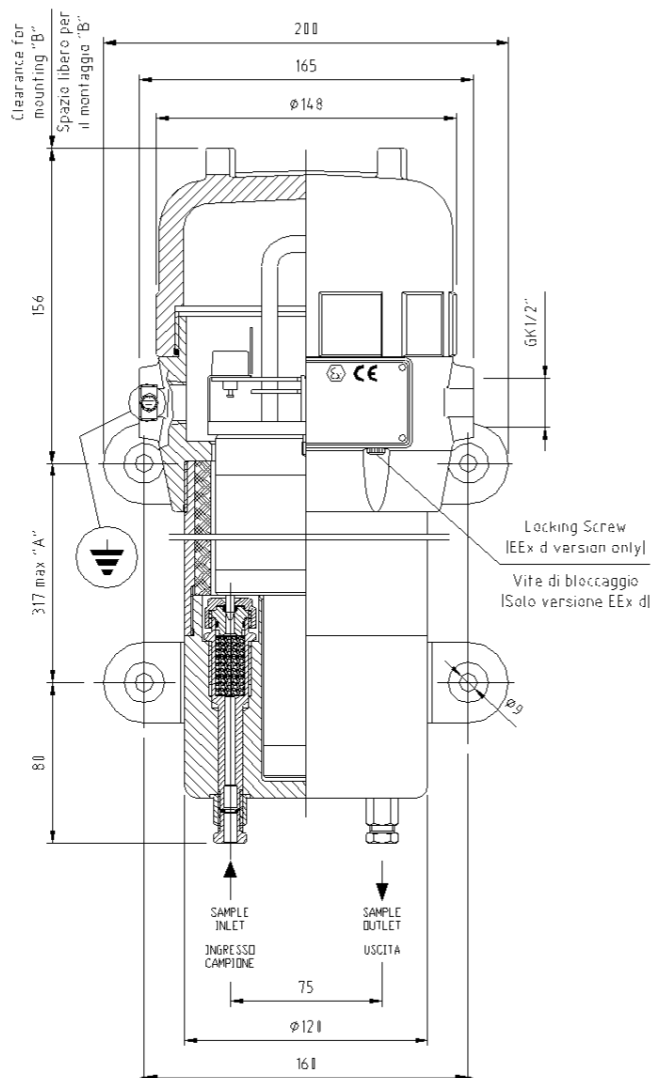

Cell Length	Quote A	Quote B
7.5 mm	174.5 mm	357.5 mm
18 mm	185 mm	368 mm
75 mm	242 mm	425 mm
150 mm	317 mm	500 mm

High Accuracy

The 8869 is an high accuracy analyzer with the inner sensing unit is temperature controlled in order to be completely insensitive to ambient temperature variations. There are no inner moving parts; installation position and eventual vibrations don't alter the accuracy and stability of the measure.

ATEX

ATEX certification for Zone 1 / Zone 21. Protection mode:



II 2 G D

Ex db IIC T6 Gb

Ex tb IIIC T85°C Db IP65

Certificates

ATEX Certificate Number CESI 03 ATEX 130

Cell Assembly

The heart of the model 8869 Infrared Analyser is the cell assembly, which consists of two helically-wound Nichrome wires which provide the I.R. source, a temperature-controlled sample cell in which the sample circulates and a detector assembly with: one measuring detector with an interference filter focused on the selected IR absorption band for the gas to be analysed; and one reference detector with an interference filter with a band able to compensate ageing effects, dirty built-up on the optical path and background gas variations.

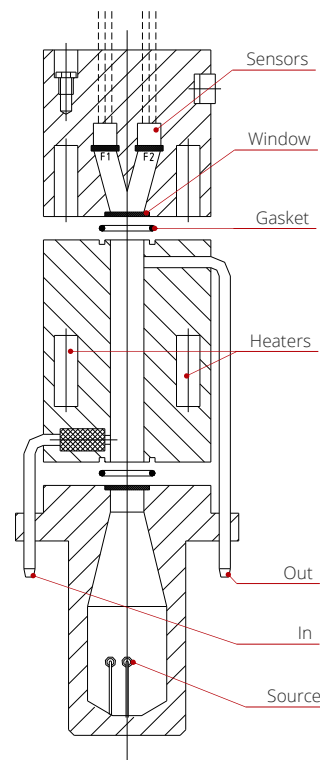

A very particular innovative technique allows a perfect system balance that eliminates drifts and the automatic restore of the sensitivity by controlling the energy that reaches the detector. This design can be expanded up to 3 gas variables.

Very Easy Maintenance



Modular construction makes maintenance extremely easy.

It's enough to unscrew the cap of the housing to have access to inner sensing unit that can be removed only by disconnecting 3 wires and unscrewing 2 screws.

Source and sample cell are very easy to disassembly and they can be cleaned up in case of erroneous entrance dust and/or particulate due to sampling system failure.

European Compliance

- Complies with Low Voltage Directive 2014/35/EU
- Complies with EMC Directive 2014/30/EU
- Complies with Directive ATEX 2014/34/EU



Ordering

Infrared Analyser	8869
1° Infrared Component		Gas / Range		[...]	[...]								
2° Infrared Component		None [N] / Yes [Y]		[...]									
		Gas / Range		[...]	[...]								
3° Infrared Component		None [N] / Yes [Y]		[...]									
		Gas / Range		[...]	[...]								
Wet Parts Materials													
316 SS										1			
Hastelloy® C276										2			
Housing													
General purpose IP65										G			
Explosion Proof (ATEX)										X			
Output Signal													
Non-normalized current output										1			
Special										9			

Gas	Code
Ammonia [NH ₃]	[01]
Carbon Dioxide [CO ₂]	[02]
Carbon Monoxide [CO]	[03]
Ethanol [C ₂ H ₆ O]	[03]
Ethylene [C ₂ H ₄]	[04]
Ethylene Oxide [C ₂ H ₄ O]	[05]
Hydrogen Chloride [HCl]	[06]
Methane [CH ₄]	[07]
Nitric Oxide [NO]	[08]
Nitrous Oxide [N ₂ O]	[09]
Propane [C ₃ H ₈]	[10]
Sulfur Dioxide [SO ₂]	[11]
Styrene [C ₈ H ₈]	[12]
Toluene [C ₇ H ₈]	[13]
Vinyl Chloride [C ₂ H ₃ Cl]	[14]
Water [H ₂ O]	[15]
Xylene [C ₈ H ₁₀]	[16]
Special	[99]

The sensing unit must be always combined with an ADEV control unit.

Minimum range depends on the gas to be measured and the stream composition

For gas and range selection (of each component) refer to codes listed in the tables.

In case of multi-gas units, not all combinations of gases are possible. Contact ADEV

The list of measurable gases aside is not complete. The 8869 analyser can measure most of the Hydrocarbons, solvents and Freon. Contact ADEV.

Range	Code
0-500 ppm	[A]
0-1000 ppm	[B]
0-2000 ppm	[C]
0-5000 ppm	[D]
0-1%	[E]
0-2%	[F]
0-5%	[G]
0-10%	[H]
0-15%	[I]
0-20%	[J]
0-25%	[K]
0-30%	[L]
0-40%	[M]
0-50%	[N]
0-60%	[O]
0-80%	[P]
0-85%	[Q]
0-90%	[R]
0-95%	[S]
0-100%	[T]
On Request	[9]

Contacts



ADEV S.r.l.



Via S. Eurosia, 27/A
20811 Cesano Maderno (MB) - Italy



+39 (0)362 641684



+39 (0)362 575058



info@adev.it

All specifications are subjected to variations for product improvement without notice.

ADEV does not accept any responsibility for potential errors or possible lack of information in this document.

We reserve all rights in this document and in the subject matter and illustrations contained therein.

Any reproduction, disclosure to third parties or utilization of its contents in whole or in parts is forbidden without prior written consent of ADEV.

