

HTK 215 Dew Point Sensor



Ensure your dry air

Monitor the dew point

The HTK 215 dew point sensor provides reliable and long term stable dew point monitoring in industrial applications.

With this model dew point measurement in refrigerant dryers becomes affordable and can replace traditional temperature measurement which often couldn't tell the real dew point.

Benefits

- Affordable dew point sensor for mid range applications such as refrigerant dryer monitoring
- Long term stability
- IP65 casing provides robust protection in rough industrial environment
- Fast response time ensures safe and reliable indication whenever dew points are out of valid ranges
- Can be installed directly into dryers through G 1/2" thread
- High accuracy of $\pm 2^{\circ}\text{C}$ dew point

Technical Data

Measuring range	Dew point $-20 \dots +5^{\circ}\text{C Td}$ / Temperature $-30 \dots +70^{\circ}\text{C}$
Dew point sensor	Polymer
Temperature sensor	NTC
Pressure sensor	N/A
Accuracy	Dew point $\pm 2^{\circ}\text{C Td}$ / Temperature 0.3°C
Operating Pressure	$-0.1 \dots 5.0 \text{ MPa}$
Operating Temperature (Medium)	$-30 \dots +70^{\circ}\text{C}$
Measured gases (Medium)	Non-corrosive gases
Response Time t_{90} (@ 4 l/min)	$-20^{\circ}\text{C Td} \rightarrow +20^{\circ}\text{C Td}$: 20 sec/ $+10^{\circ}\text{C Td} \rightarrow -20^{\circ}\text{C Td}$: 60 sec
Ambient Temperature	$-20 \dots +50^{\circ}\text{C}$
Ambient Humidity	$0 \dots 100\% \text{ rH}$
Supply Voltage	$12 \dots 30 \text{ VDC}$
Current consumption	$20 \text{ mA @ } 24 \text{ VDC}$
Output signals	$4 \dots 20 \text{ mA } 2\text{-Wire}$
Electrical connection	M12, 5-poles
Process connection	G 1/2" thread (ISO 228/1)/ Stainless steel 1.4301 (SUS 304)
Casing material	Zinc alloy
Classification	IP65
EMC	IEC 61326-1
Approval	-
Sensor protection	Sinter filter
Transport Temperature	$-30 \dots +70^{\circ}\text{C}$
Storage Temperature	$-20 \dots +50^{\circ}\text{C}$
Weight	195 g

Dimension Drawing

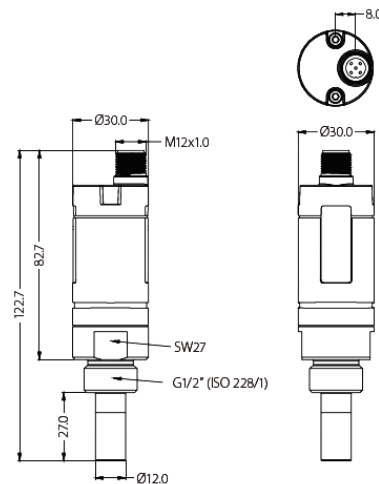

HTK Hamburg GmbH

Oehleckerring 32 • 22419 Hamburg

Phone: +49 (0)40 - 600 38 38 - 0 • Fax: +49 (0)40 - 600 38 38 - 99

info@htk-hamburg.com



© Copyright 2019 - All contents of this document, in particular Texts, photographs and graphics are protected by copyright. All rights, including reproduction, publication, processing and translation are reserved, HTK Hamburg GmbH. Please contact HTK Hamburg GmbH if you would like to use the contents of this document.

Rev.l_082020_HTK 215_engl • Subject to change



We control GASES - since 1978

