

HTK 212 Dew Point Sensor



Very fast response time

Ensures safe and reliable measurements

The dew point sensor HTK 212 provides reliable and long term stable dew point monitoring in industrial applications. The newly developed sensor features improved signal and stability in demanding industrial applications. It makes it an ideal choice for dew point measurements in desiccant dryers.

Mode of operation

The measured dew point is output via a 4-20 mA signal output. The compact size of the sensor makes it an ideal choice for installations in tight environments.

Sensor parameters such as analogue output scaling, alarm values, units, etc, can be easily changed. HTK will adjust the sensor according to your requirements.

Technical Data

Measuring range	Dew point -50 ... +20°C Td/ Temperature -30 ... +70°C
Dew point sensor	Polymer
Temperature sensor	Pt100
Pressure sensor	N/A
Accuracy	Dew point ±2°C Td/ Temperature 0.3°C
Operating Pressure	-0.1 ... 5.0 MPa
Operating Temperature (Medium)	-30 ... +70°C
Measured gases (Medium)	Non-corrosive gases
Response Time t90 (@ 4 l/min)	-50°C Td -> 0°C Td = 20 sec/ 0°C Td -> -50°C Td = 180 sec
Ambient Temperature	-20 ... +50°C
Ambient Humidity	0 ... 100% rH
Supply Voltage	12 ... 30 VDC
Current consumption	30 mA @ 24 VDC
Output signals	4 ... 20 mA 3-Wire
Electrical connection	M12, 5-poles
Process connection	G 1/2" thread (ISO 228/1)/ Stainless steel 1.4301 (SUS 304)
Casing material	Zinc alloy
Classification	IP65
EMC	IEC 61326-1
Approval	-
Sensor protection	Sinter filter
Transport Temperature	-30 ... +70°C
Storage Temperature	-20 ... +50°C
Weight	195 g

Benefits

- Dew point sensor for low dew point applications down to -50°C Td
- Long term stability
- IP65 casing provides robust protection in rough industrial environment
- Fast response time ensures safe and reliable indication whenever dew points are out of valid ranges
- Can be installed directly into dryers through G 1/2" thread
- High accuracy of ±2°C dew point

Dimension Drawing

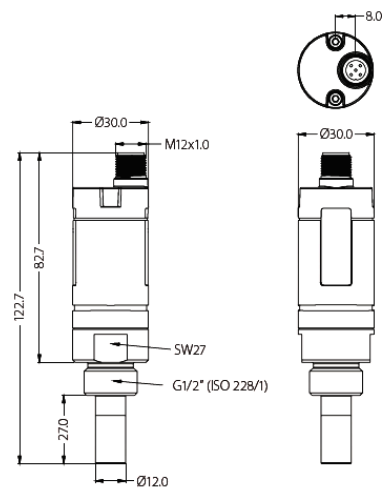

HTK Hamburg GmbH

Frahmredder 49 • 22393 Hamburg

Phone: +49 (0)40 - 600 38 38 - 0 • Fax: +49 (0)40 - 600 38 38 - 99

info@htk-hamburg.com



© Copyright 2019 - All contents of this document, in particular Texts, photographs and graphics are protected by copyright. All rights, including reproduction, publication, processing and translation are reserved, HTK Hamburg GmbH. Please contact HTK Hamburg GmbH if you would like to use the contents of this document.

Rev.1_082020_HTK 212_engl • Subject to change



We control GASES - since 1978

