



Measure consumption and flow

Optimize process efficiency

- Pipes sizes available: DN15, DN20, DN32, DN40, DN50, DN65, DN80
- Fits your needs: various process connections available (R-thread, EN 1092-1 flange or ANSI flange)
- Exchangeable sensor unit (easy sensor swap)

Benefits

- Measures standard flow, mass flow and consumption
- Thermal mass flow, independent of pressure and temperature changes
- IP65 casing provides robust protection in rough industrial environment
- Very fast response time
- High accuracy and wide measuring range
- Isolated mA and pulse output signals or Modbus/RTU or Modbus/TCP interface
- Selectable gas type (Some gases require real gas calibration!)
- Sensor can be calibrated in 2 different gases

Installation and Sensor Removal



The MFM 1200 sensor unit can be easily removed for calibration. (Closing cap separately available)

Network integration

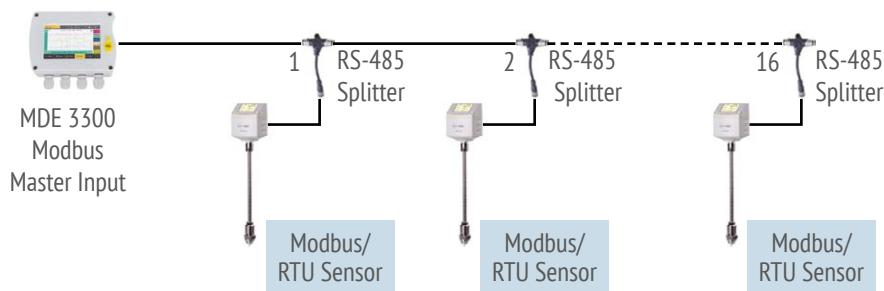

Sensors can be easily integrated into a Modbus network



Analysers from HTK

We are your partner for tailor-made gas analysis technology

The use of fixed and mobile gas analysers is widespread in many industries, and the demand continues to grow.

HTK Hamburg develops and builds equipment to provide effective solutions, from the small manual analyser up to the complex analysis unit in the food sector, welding & cutting and in many other industries.

Planning, manufacturing, service and calibrating analysers for the measuring gases such as O₂, CO₂, H₂, SF₆ - and many more - isn't a challenge for us; it's our mission each and every day.

Our aim is to ensure safe, consistent and accurate analysis in your process - thus maintaining quality.

Technical Data	
Accuracy	1.5% of reading + 0.3% full scale (Optional 1% of reading)
Repeatability	0.25% of reading
Sampling rate	> 10 samples / sec
Reference conditions	Can be set by user. Standard conditions are Ps = 0.1 MPa and Ts = 20°C
Medium conditions	-30 ... +140°C / relative humidity < 90% no condensation
Transport temperature	-30 ... +70°C
Material	Metal parts 1.4404 (SUS 316L) Casing PC + ABS Sensor: Ceramic with glass coating
Classification	IP65
Electrical connection	2 x M12, 5 poles (2 x M12 plug with screw terminals included)
Approvals	CE, RoHS, FCC
Operating temperature	-30 ... +140°C fluid temperature -30 ... +70°C casing -10 ... +50°C casing with display
Operating pressure	0 ... 1.6 MPa (Optional: 4.0 MPa)
Analogue output	Signal: 4 ... 20 mA, isolated Scale: 0 ... max flow Max. Load: 250R
Pulse output	Signal: Isolated switch output, normally open, Max 30 VDC, 20 mA Scaling: 1 pulse per consumption unit
Modbus output	Isolated RS-485 with Modbus/RTU protocol or Modbus/TCP output
Power supply	15 ... 30 VDC / 200 mA

Volumetric flow ranges

Inch	Measuring range from to
½" (DN15)	0.5 ... 90 m ³ /h
¾" (DN20)	0.9 ... 170 m ³ /h
1" (DN25)	1.5 ... 290 m ³ /h
1¼" (DN32)	2 ... 500 m ³ /h
1½" (DN40)	3 ... 700 m ³ /h
2" (DN50)	4 ... 1000 m ³ /h
2½" (DN65)	6 ... 1500 m ³ /h
3" (DN80)	8 ... 2500 m ³ /h

Stated measuring ranges under following conditions:

- Standard flow in air
- Reference pressure: 1000 hPa
- Reference temperature: +20°C

The table above shows the air flow ranges for pipe sizes up to DN80 at standard conditions. At other reference conditions and gas types the flow range may vary, please contact your local sales support. Furthermore it is possible to measure the air flow in bigger pipes (> DN80), for this please contact your local sales support.

MFM 1200



Optional flow conditioner

No more straight inlet requirements

Optional flow conditioner eliminates the straight pipe inlet requirement



MFM 1200 thread type

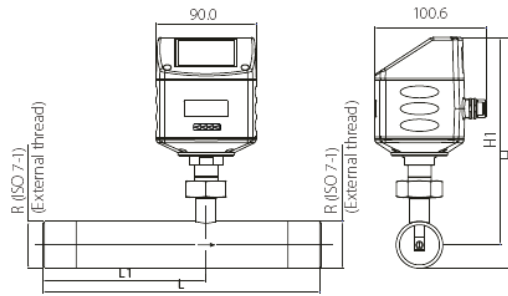

Pipe nominal size inch (DN)	L Total length (mm)	L1 Total length (mm)	H Total Height (mm)	H1 from pipecenter to casing top (mm)	External thread
½" (DN15)	300	210	197.4	186.7	R½"
¾" (DN20)	475	275	200.2	186.7	R¾"
1" (DN25)	475	275	203.6	186.7	R1"
1¼" (DN32)	475	275	207.9	186.7	R1¼"
1½" (DN40)	475	275	210.9	186.7	R1½"
2" (DN50)	475	275	216.9	186.7	R2"
2½" (DN65)	475	275	232.7	194.6	R2½"
3" (DN80)	475	275	245.5	201.0	R3"

MFM 1200 flange type

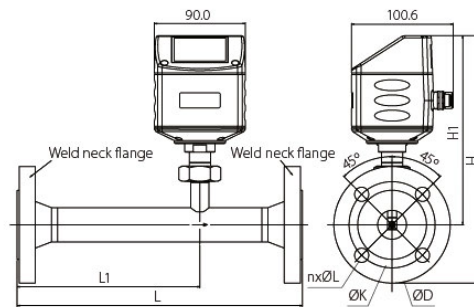

Pipe nominal size inch (DN)	L Total length (mm)	L1 Total length (mm)	H Total Height (mm)	H1 from pipecenter to casing top (mm)
½" (DN15)	300	210	234.2	186.7
¾" (DN20)	475	275	239.2	186.7
1" (DN25)	475	275	244.2	186.7
1¼" (DN32)	475	275	256.7	186.7
1½" (DN40)	475	275	261.7	186.7
2" (DN50)	475	275	269.2	186.7
2½" (DN65)	475	275	287.1	194.6
3" (DN80)	475	275	301.0	201.0

Optional flow conditioner for MFM 1200

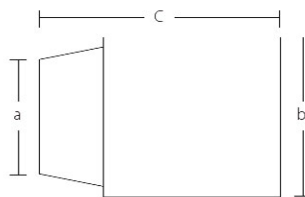

DN	a	b in mm	c in mm
DN15	R 1/2"	24	64
DN20	R 3/4"	32	69
DN25	R 1"	37	75
DN32	R 1.25"	45	92
DN40	R 1.5"	54	92
DN50	R 2"	68	105
DN65	R 2.5"	80	128
DN80	R 3"	95	142



HTK Hamburg GmbH
Frahredder 49
22393 Hamburg

Phone: +49 (0)40 - 600 38 38 - 0
Fax: +49 (0)40 - 600 38 38 - 99
info@htk-hamburg.com

© Copyright 2019 - All contents of this document, in particular Texts, photographs and graphics are protected by copyright. All rights, including reproduction, publication, processing and translation are reserved, HTK Hamburg GmbH. Please contact HTK Hamburg GmbH if you would like to use the contents of this document.

Rev.III_082020_MFM 1200_engl • Subject to change



We control GASES - since 1978

